

When mechanical seals were first developed, most pump shafts were sealed with packing, so the mechanical seal designs were required to fit into a packing stuffing box. However, over the years, pump users and manufacturers came to realize that the tight confines of a stuffing box did not allow enough liquid circulation around the mechanical seal to remove sufficient heat and/or to keep solids in the pumped liquid away from the seal faces, to achieve desired seal life. This led to the development of “seal chambers” that provide more space around the mechanical seal, which promotes circulation to expel solids and air/vapors from around the mechanical seal faces, and reduce seal face temperatures, thus increasing MTBR.

The major goal of seal chamber design is to provide an environment that allows seal faces to run cooler and with greater stability. Select the proper environmental control to insure maximum mechanical seal life.

Standard Bore

The standard bore stuffing box is the lowest cost design. Originally designed for mechanical packing. Also accommodates mechanical seals.

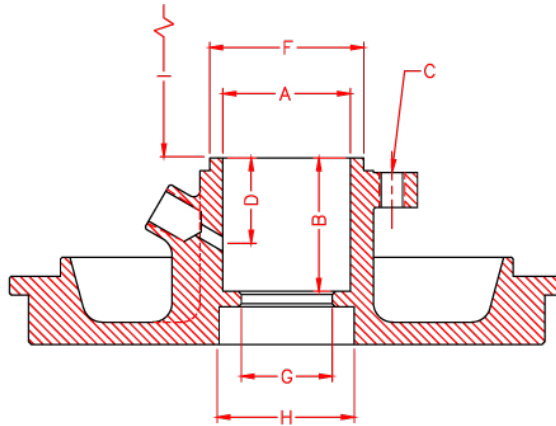

PUMP FRAME	A	B	C		D	E	F	G	H	I
			B.C.	TAP						OBSTRUCTION
STO	2.00	2.13	3.25	3/8-16 UNC	0.97	1/4-18 NPT	2.39	1.40	N/A	2.18
MTO	2.50	2.61	4.13	1/2-13 UNC	1.56	3/8-18 NPT	3.02	1.78	2.65	3.00
LTO	2.88	2.63	4.50	1/2-13 UNC	1.56	3/8-18 NPT	3.52	2.15	2.63	3.00
XLO	3.38	3.00	5.38	5/8-11 UNC	1.75	3/8-18 NPT	4.37	2.53	3.38	2.90
XLO-17	3.63	3.00	5.38	5/8-11 UNC	1.63	1/4-18 NPT	4.38	2.78	3.50	2.90

Large Bore

Designed for mechanical seals. Enlarged area around the mechanical seal which promotes cooling and seal face lubrication.

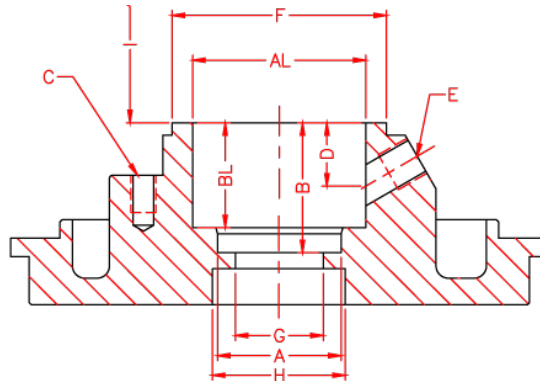

PUMP FRAME	A	AL	B	BL	C		D	E	F	G	H	I OBSTRUCTION
					B.C.	TAP						
STO	2.00	2.86	2.13	1.69	4.50	3/8-16 UNC	0.88	1/4-18 NPT	3.60	1.40	N/A	2.18
MTO	2.50	3.50	2.61	2.12	5.50	1/2-13 UNC	1.28	1/2-14 NPT	4.34	1.78	2.69	3.00
LTO	2.88	3.88	2.63	2.06	6.00	5/8-11 UNC	1.38	3/8-18 NPT	4.71	2.16	2.77	3.00
XLO	3.38	4.75	3.00	2.50	6.75	5/8-11 UNC	1.38	3/8-18 NPT	5.45	2.53	3.38	2.90
XLO-17	3.63	4.75	3.00	2.45	6.75	5/8-11 UNC	1.41	3/8-18 NPT	5.45	2.75	3.50	2.90

Taper Bore

Designed for mechanical seals. The larger area promotes lower seal face temperature's, and the taper allows for venting and draining of the chamber. Flow modifiers direct axial flow and keep solids suspended, minimizing seal erosion.

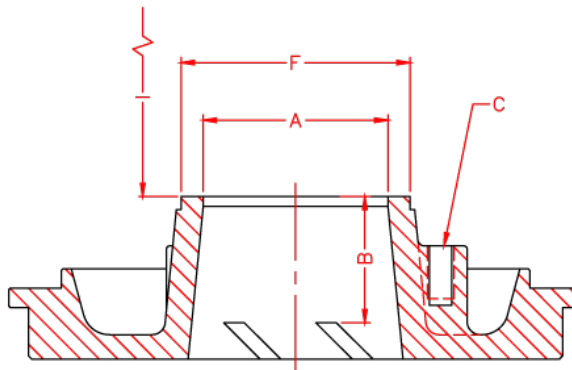

PUMP FRAME	A	B	C		F	I OBSTRUCTION
			B.C.	TAP		
STO	2.88	1.75	4.50	3/8-16 UNC	3.60	2.18
MTO	3.50	2.23	5.50	1/2-13 UNC	4.34	3.00
LTO	3.88	2.21	6.00	5/8-11 UNC	4.71	3.00
XLO	4.75	2.02	6.75	5/8-11 UNC	5.45	2.90
XLO-17	4.75	2.02	6.75	5/8-11 UNC	5.45	2.90