

SUMMIT™

SPPC

Installation, Operation, and Maintenance Manual
Model: SPPC Sealed Gear Joint Pump

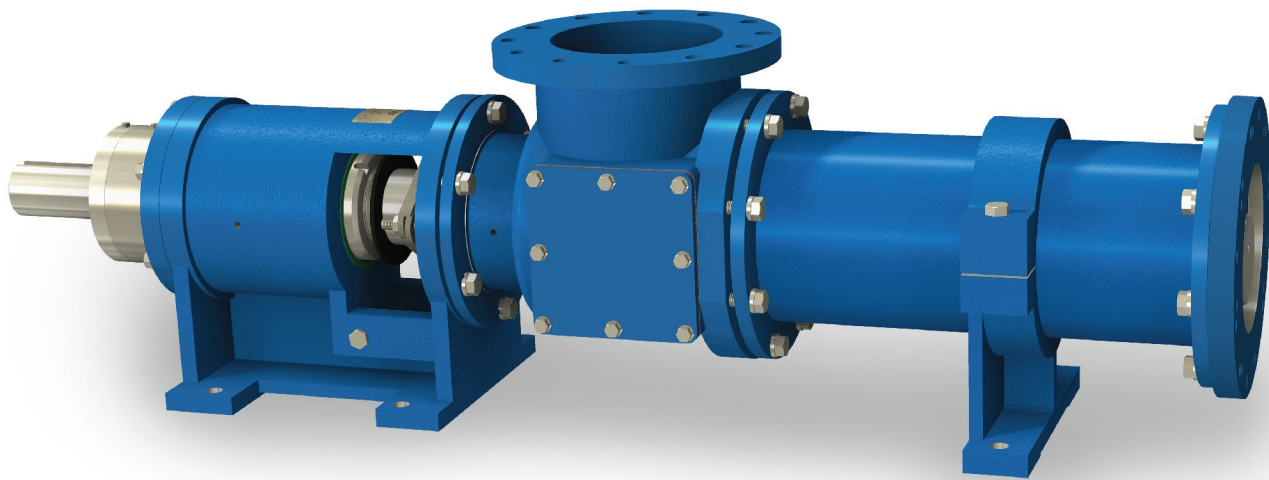

SPPC

Progressive Cavity Pumps



SUMMIT™
PUMP, Inc

www.SUMMITPUMP.com



i. WARRANTY

Pumping units assembled by Summit Pump, Inc., Green Bay, WI are guaranteed to be free from defects in material and workmanship for one year from date of shipment from factory in Green Bay, WI. The obligation under this warranty, statutory or otherwise, is limited to replacement or repair at Green Bay, WI, of such part as shall appear to us upon inspection at such point, to have been defective in material or workmanship.

This warranty does not obligate Summit Pump, Inc. to bear the cost of labor or transportation charges in connection with replacement or repair of defective parts; nor shall it apply to a pump upon which repairs or alterations have been made unless authorized by Summit Pump, Inc.

No warranty is made in respect to engines, motors, or trade accessories, such being subject to warranties of their respective manufacturers.

No express implied or statutory warranty, other than herein set forth is made or authorized to be made by Summit Pump, Inc.

In no event shall Summit Pump, Inc. be liable for consequential damages or contingent liabilities arising out of the failure of any Summit Pump, Inc. pump or parts thereof to operate properly.

ii. LIABILITY

Summit Pump, Inc. shall not be liable for personal physical injury, damage or delays caused by failure to follow the instructions and procedures for installation, operation and maintenance contained in this manual.

The equipment is not for use in or with any nuclear facility or fire sprinkler system. Buyer accepts the responsibility for insuring that the equipment is not used in violation and Buyer shall indemnify and hold Seller harmless from any and all liability (including such liability resulting from seller's negligence) arising out of said improper use.

iii. COPYRIGHT

This Installation, Operation, and Maintenance Manual contains proprietary information, which is protected by copyright. No part of this Installation, Operation, and Maintenance Manual may be photocopied or reproduced without prior written consent from Summit Pump.

The information contained herein is for informational use only and is subject to change without notice. Summit Pump assumes no responsibility or liability for any errors or inaccuracies that may appear in this manual.



1 CONTENTS

I. WARRANTY	III	5.5 FIRST RUN CHECK	12
II. LIABILITY	III	5.5.1 Start Up	12
III. COPYRIGHT	III	5.5.2 Shut Down	13
1 CONTENTS	V	6 APPENDIX A – MAINTENANCE	
2 INTRODUCTION	1	TIMETABLE.....	14
2.1 SAFETY	1	6.1 DAILY MAINTENANCE	14
2.2 PUMP SAFETY WARNINGS	2	6.2 THREE MONTH MAINTENANCE	14
2.3 NOMENCLATURE	2	6.3 SIX MONTH MAINTENANCE.....	14
2.3.1 Size Designation	2	6.4 YEARLY MAINTENANCE	14
2.3.2 Materials of Construction.....	2	7 APPENDIX B –	
2.3.3 Trim Code	3	TROUBLESHOOTING.....	15
3 RECEIPT AND STORAGE.....	4	7.1 PUMP PROBLEMS	15
3.1 RECEIVING THE PUMP	4	7.2 PROBABLE CAUSE AND REMEDY.....	15
3.2 STORING THE PUMP	4	8 APPENDIX C – DISASSEMBLY	
3.2.1 Temporary	4	MODEL SPPC	16
3.2.2 Long Term.....	4	8.1 DISASSEMBLY MODEL SPPC.....	16
3.3 HANDLING	4	9 APPENDIX C – ASSEMBLY	
3.4 LIFTING	4	MODEL SPPC	19
4 INSTALLATION	5	9.1 ASSEMBLY MODEL SPPC	19
4.1 GENERAL	5	9.1.1 Lubrication	19
4.2 LOCATION	5	9.1.2 Packing.....	19
4.3 BASE PLATE	5	9.1.3 Suction & Bearing Housing.....	19
4.4 FOUNDATION	5	9.1.4 Bearing/Drive Shaft Assembly.....	20
4.4.1 Concrete Sub-Base.....	5	9.1.5 Rotor/Stator	20
4.5 BASEPLATE GROUTING	6	9.1.6 Rotor Gear Joint	20
4.6 PIPING CONNECTION – SUCTION /		9.1.7 Rotor/Stator to Drive End.....	21
DISCHARGE	6	9.1.8 Gear Joint: Drive End.....	21
4.6.1 Suction Piping	7	9.1.9 Stator Support & Discharge.....	22
4.6.2 Suction Housing Rotation	7	9.1.10 Final Steps	22
4.6.3 Discharge Piping	7	10 APPENDIX D – SECTION VIEW	
4.7 ALIGNMENT	7	SPPC.....	24
4.7.1 Coupling Connected Units.....	7	11 APPENDIX E – DIMENSIONS .	25
4.7.2 Belt Driven Units.....	8	11.1 STUFFING BOX.....	25
4.7.3 Alignment Checks	8	11.2 OVERALL DIMENSIONS	26
5 OPERATION	9	12 TORQUE GUIDELINES	28
5.1 CHECKING ROTATION	9	12.1 BOLT TORQUES.....	28
5.2 LUBRICATION	9	12.2 CONNECTING ROD LOCK NUTS.....	28
5.3 PACKING	10		
5.3.1 Greased Packing	10		
5.3.2 Water Flushed Packing.....	11		
5.4 MECHANICAL SEAL.....	11		
5.4.1 Type 1 Mechanical Seal	12		

2 INTRODUCTION

This installation, operation, and maintenance manual is designed to help you achieve the best performance and longest life from your Summit Pump. This pump is a progressing cavity pump. It is designed for high viscosity liquids.

This pump is a single helical rotor rolling eccentrically in a double helix stator which creates the differential pressure. The rotor turns in conjunction with the stator which has a series of sealed cavities 180° apart. As one cavity diminishes the opposing cavity increases at exactly the same rate. Thus the sum of the two discharges is a constant volume. The result is a pulsation-free positive displacement flow utilizing no valves.

If there are any questions regarding this pump or its application, which are not covered in this manual, please contact your local Summit Pump distributor.

For information or technical assistance on the driver service, contact the driver manufacturer's local dealer or representative.

2.1 SAFETY

The following message types are used in this manual to alert maintenance personnel to procedures that require special attention for the protection and safety of both personnel and equipment:

 DANGER
Imminently hazardous situation which, if not avoided, will result in death or serious injury.

 WARNING
Potentially hazardous situation which, if not avoided, could result in death or serious injury.

 CAUTION
Potentially hazardous situation which, if not avoided, may result in minor or moderate injury.

NOTICE
Includes Information on operation, maintenance, rules or directions. May indicate possible property damage.

2.2 PUMP SAFETY WARNINGS

The safety information below should be followed and observed to prevent damage to equipment, injury or death to operators:

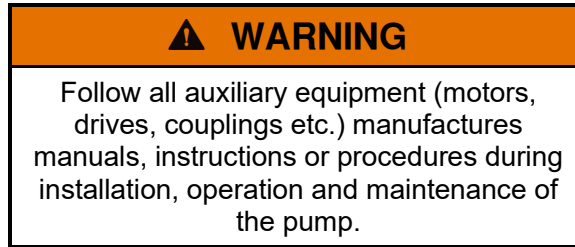
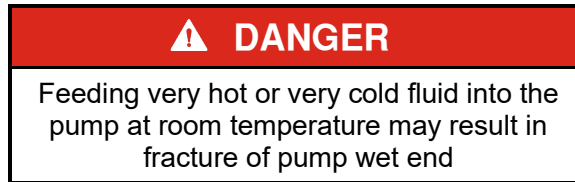

2.3 NOMENCLATURE

On page 29 of this manual, record the nameplate data from your pump. This will assist with any maintenance questions or pump identification in the future.

Summit's SPPC Sealed Gear Pumps are essentially identified by frame size. The pump's identification number (Example: 2SPE022 CDQ AAA) consists of the pump's **size designation** (first set of characters, i.e. 2SPE022), **materials of construction** (Middle 3 letters, i.e. CDQ), then the **trim code** (last three letters, i.e. AAA).

2.3.1 Size Designation

The first character is always a number which indicates the number of stages the pump has. (i.e. 2SPE022 is a "2" stage pump)

The next three letters i.e. "SPE" represents a standard relationship with the pumping elements, housing, bearings and drive shaft. Where "E" in "SPE" can be any of the following letters: E, F, G, H, J, and K designating the frame size.

Last three numbers approximately indicates the number of GPM per 100 RPM (i.e. 022 gives 21.89 GPM/100RPM). Also, if this number is followed by the letter "E" (example: 2SPF054E), this indicates the rotor and stator are double and triple helix extrusions respectively.

2.3.2 Materials of Construction

Materials of Construction (i.e. CDQ) are represented though a series of letters, usually 3 letters. The first letter indicates the housing material. The second letter indicates the minor metallic parts in contact with the pumping-solution (Wet able parts: drive shaft, pins, connecting rod, rotor...). The third letter indicates only the malleable material of the stator. This does not include the outer shell of the stator. The following list decodes the Materials of Construction.

First and Second Letters:

- C: Cast Iron
- D: Alloy Steel
- E: Carpenter® 20 Stainless Steel
- G: 416 Stainless Steel
- H: Hastelloy® “C”
- J: 17-4 PH Stainless Steel
- M: Monel®
- S: 316 Stainless Steel
- W: Cast Steel
- X: Special to Application

Third Letter:

- B: EPDM 300, 70 Durometer
- C: Nitrile 103, 50 Durometer
- D: Tool Steel
- E: Nitrile 110, 70 Durometer
- F: Fluoroelastomer 500, 75 Durometer
- G: 416 Stainless Steel
- H: Hastelloy® “C”
- J: 17-4 PH Stainless Steel
- K: Hypalon® 800, 70 Durometer
- M: Nitrile 100M, 70 Durometer
- P: Thiokol® 70 Durometer
- Q: Nitrile 100, 70 Durometer
- R: Natural Rubber 200, 55 Durometer
- I: Teflon® 15% glass
- U: Urethane 70 Durometer
- X: Special to Application
- Y: Nitrile 145
- Z: White Nitrile 150, 70 Durometer

2.3.3 Trim Code

The “Trim Code” (i.e. “AAA”) is used to show the pump construction. Sealing variations are represented by the first letter; internal variations by the second letter and rotor variations by the third letter. With the letter “A” indicating standard construction as shown in the list below.

First Letter

- A: Braided Teflon® & Graphite Packing (Black)
- C: Braided Teflon® Packing (White)
- D: Double Mechanical Seal
- F: Braided Teflon® Food Grade Packing
- G: 100% Graphite Packing
- H: Flush Packing Gland
- S: Single Mechanical Seal
- W: Water Flush
- X: Special to Application

Second Letter

- A: Standard Plated Shaft
- B: Non-plated Shaft
- C: Solid Drive Shaft Configuration
- E: Extension Tube with Extended Auger
- F: Extended Drive Shaft (for back stop or large pulley)
- G: Ceramic Coated Drive Shaft
- K: Tungsten Carbide Coated Drive Shaft
- M: Chromium Carbide Coated Drive Shaft
- R: Fiber Deflector
- S: Shaft Sleeve
- X: Special to Application

Third Letter

- A: Standard Size with Chrome Plating
- B: Non-plated
- C: Standard Undersize
- E: Standard Oversize
- G: Ceramic Coating
- K: Tungsten Carbide Coating
- M: Chromium Carbide Coating
- X: Special to Application

® Registered Trademarks –

Carpenter®. 1981. Carpenter Technology Corporation. Reading, Pennsylvania, USA.
 Hastelloy®. 1955. Union Carbide and Carbon Corp. New York, New York, USA.
 Hypalon®. 1993. E.I. DuPont de Nemours and Company. Wilmington, Delaware, USA.

Monel®. 1997. Inco Alloys International, Inc. Huntington, West Virginia, USA.
 Teflon®. 2005. E.I. DuPont de Nemours and Company. Wilmington, Delaware, USA.
 Thiokol®. 1957. Thiokol Chemical Corp. Trenton, New Jersey, USA.

3 RECEIPT AND STORAGE

3.1 RECEIVING THE PUMP

Immediately upon arrival, carefully inspect the pump for evidence of damage during transit. Immediately report any damage to your local Summit Pump distributor.

3.2 STORING THE PUMP

3.2.1 *Temporary*

Temporary storage: less than six months.

1. Store pump in a clean, dry place, free from extreme swings in temperature and humidity.
2. Cover with a protective covering to reduce dust contamination.
3. Rotate the shaft once a week to avoid the stator elastomers forming a set condition. If this happens, upon starting the pump the required torque to overcome static friction may damage equipment.
4. Take off inspection plates and or drain plugs to allow the pump to dry. When pump is dry re-install inspection plates and plugs to keep pump sanitary.
5. Loosen the packing gland nuts; remove the gland and packing rings and lantern ring. Apply grease to the stuffing box I.D. & packing rings. Return the packing and lantern rings to their position in the stuffing box. Snug down the packing gland nuts finger tight. Do not use grease if gland is water flushed. Only a small amount of light oil should be applied in this scenario.

3.2.2 *Long Term*

Long Term Storage: more than six months.

1. Follow temporary storage guidelines 1-5.
2. Coat all unpainted and machined surfaces with a rust inhibitor, such as LPS-3.
3. The removal of drive belts is also recommended per manufacturers recommendations.

3.3 HANDLING

Pump unit boxes and crates may be unloaded using a forklift or slings depending on size and package construction.

⚠ WARNING

Pump and assemblies are heavy, improper handling could result in serious injury.

3.4 LIFTING

To avoid damage to pump and/or motor use a nylon, chain, or a wire rope sling. The slings should be placed so lift is equally supported at four or more points.

⚠ WARNING

Be sure all components are securely fastened to baseplate before lifting

4 INSTALLATION

4.1 GENERAL

Summit Pumps are fully assembled at the factory. The pumps are ready to be installed and put into service. Follow any instructions tagged on the pump.

4.2 LOCATION

If the pump is going to have a water flush it should be located as close as possible to a supply of water. Other location considerations are easy access for inspection, maintenance and ample overhead space for lifting with crane or hoist.

4.3 BASE PLATE

Each pump unit should be mounted on a fabricated steel base plate. Usual base configurations are inline, piggy back and L-shape. The base plate should be mounted on a concrete sub base 4" to 8" longer and wider than the fabricated baseplate.

4.4 FOUNDATION

4.4.1 Concrete Sub-Base

The concrete sub foundation performs a number of functions. It must support the weight of the entire pump assembly, maintain the alignment of all system components, and absorb the loads, forces and vibrations that are developed under normal operating conditions. The concrete material used must be top quality and conform to local building codes as well as the contractor's strength requirements. Reinforcing bars and mesh should be used as required. The mounting surface of the concrete foundation must be flat and level beneath the footprint of the sub-base, or the pump could be installed out of square. This could create problems aligning the piping, place extra loads on the couplings and bearings, and alter the operating levels of lubricants or hydraulic fluids in the system. It is recommended that the top surface of the slab be held flat and level to at least F50 according to American Concrete Institute (#117) and the Canadian Standards Association (#A23.1) which is approximately 1/8" per 10 foot. The sub base height is usually determined by the process piping runs and elevation.

The weight of the sub foundation should be 3-5 times the weight of the pump, motor and baseplate. Dimensionally, it should be 4" to 8" longer and wider than the polymer concrete or fabricated steel baseplate. Anchor bolts are installed in pipe sleeves. The pipe diameter is 2.5 times larger than the anchor bolt diameter. This sleeve/bolt assembly is embedded in the base when poured. Anchor bolt sizes: 1"-8UNC. Length is 7.5" to 10" depending on base thickness and overall size.

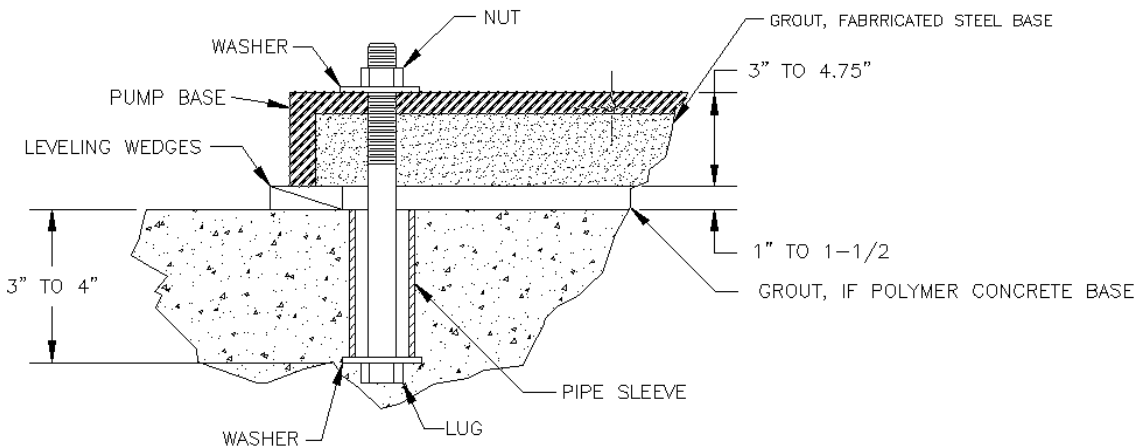

Figure 1: Anchor Bolt configuration

4.5 BASEPLATE GROUTING

1. This grouting instruction assumes a concrete sub base has been put in place to accept the baseplate. The subbase should be clean of dirt, oil and any other debris.
2. Shims/wedges should be wood.

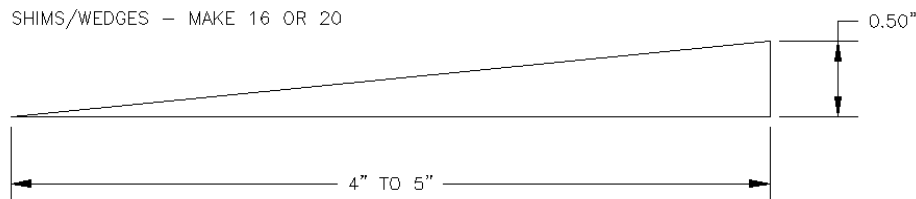

Figure 2: Wooden Wedges

3. Shims/wedges should be placed on the sub base, as shown in **Figure 4-4**. Use 2 to 3 per stack to obtain desired gap between baseplate and sub-base. Normal gap is 1" to 1-1/2".
4. Carefully lower baseplate with pump and motor onto sub base over anchor bolts.
5. Level baseplate to 0.125" over length and 0.088" in over width.
6. When leveling is complete, uniformly hand tighten the anchor bolts.
7. Build a plywood form around baseplate supported on the sub base. It should be 3" high and 1" to 1.5" larger than the baseplate. Its size should be large enough to include the shims or wedges that are left in place.

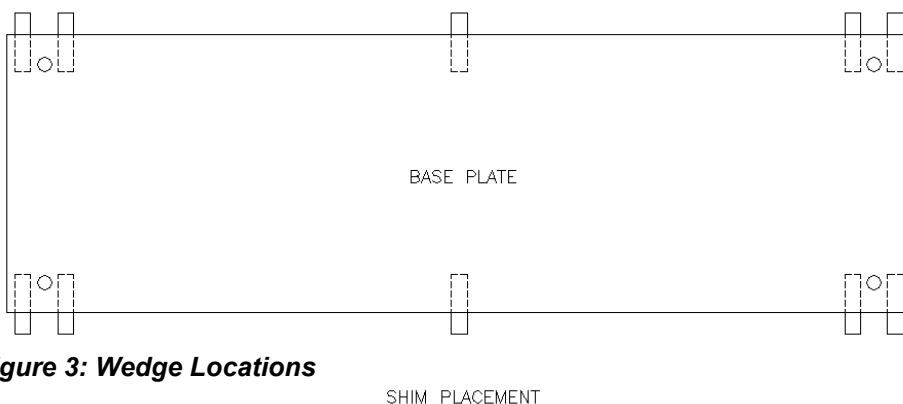
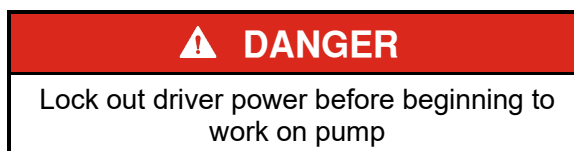

Figure 3: Wedge Locations

8. Use a high quality non-shrinking epoxy grout, following manufacturer's mixing and installation instructions.
9. When grout has cured, per grout manufacturer's recommended cure time, tighten anchor bolts till secure.
10. When grouting is complete, check coupling alignment and re-align as necessary.

4.6 PIPING CONNECTION – SUCTION / DISCHARGE



Connect piping in a manner that is as short and direct as possible. Independent pipe supports and anchors must be used in all installations. **Never support piping with pump flanges.** Ideally, you should place a short length of flexible or bellows type spool directly adjacent to the pump flange.

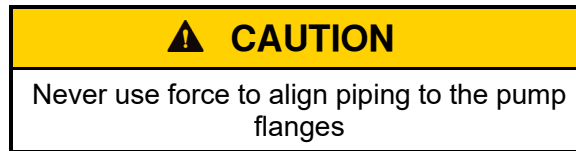

4.6.1 Suction Piping

The piping used should be as short as possible. Piping line size should be the same diameter as the suction nozzle. This may not always be the case as high viscosity or flow velocity may cause a change in size. All elbows 90° or 45° should be a long-sweep. Any piping that causes air to become trapped should be avoided.

4.6.2 Suction Housing Rotation

Suction housing can be rotated to any position within the centerline of the pump. Rotation of the suction housing is accomplished by loosen the bolts securing the clamp ring to the bearing housing. Next, remove the packing gland halves then the packing studs. Loosen the stator support cap at the suction housing. Stator and discharge flange will now rotate together.

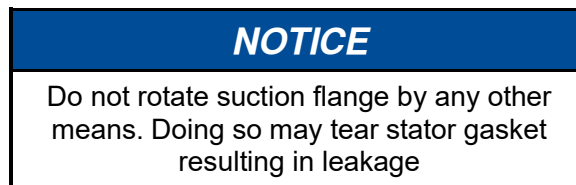

4.6.3 Discharge Piping

Generally the diameter of the discharge piping should be the same as the pump's discharge. In certain circumstances, this will not be the case as the fluid being pumped will cause you to use different sized pipe. In order to ease the maintenance time of changing out the stator a length of piping twice the length of the connecting rod should be installed to the discharge port.

4.7 ALIGNMENT

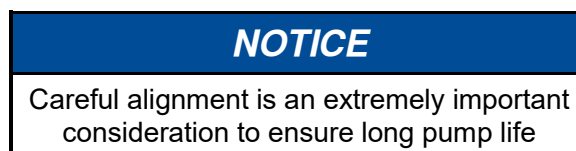

4.7.1 Coupling Connected Units

In-line configurations are shipped with the pump and motor leveled on the base plate with the coupling disconnected. If the pump and driver were aligned at the factory, that alignment will be disturbed during shipment. Alignment must be rechecked. If alignment is necessary, align the motor to the pump not the pump to the motor. Check both parallel and angular alignments. Final alignment should be within 0.005" in all planes at operating temperature.

4.7.2 Belt Driven Units

Check belt and sleeve alignment. Check belts for proper belt tension. Tension requirements will vary with the type of belt, centerline distance and belt speeds. Consult belt manufacture for specific recommendation.

4.7.3 Alignment Checks

Alignment checking needs to be done several times prior to pump start up. Those alignment recommendations are as follows:

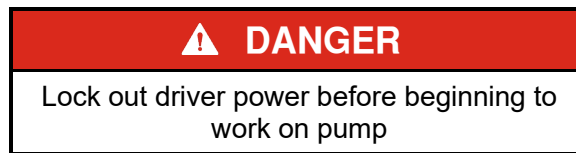

1. Prior to grouting, to remedy misalignment caused by transportation
2. After grouting, to correct any changes that occurred during grouting.
3. After piping is connected, Check alignments to ensure possible pipe strains have not changed alignment.
4. Hot alignment, after the pump has reached operating temperature, if the pump is used in high temperature service.
5. Alignment is accomplished by adding or removing shims under the motor feet and moving the motor as required eliminating the misalignment.

5 OPERATION

5.1 CHECKING ROTATION



1. Lockout power to drive.
2. Remove coupling guard.
3. Remove coupling grid/sleeve element so that the motor half of coupling can spin free from the pump half.
4. Unlock power to motor.
5. Clear personnel from immediate area, jog motor just enough to determine direction of rotation. Rotation must be same as arrow on pump.
6. If rotation is the same direction, lockout motor and reassemble coupling grid/sleeve to connect pump half.
7. If the pump is rotating in the wrong direction the electrical wiring will need to be adjusted by qualified personnel. Then repeat Step 4, 5 and 6.
8. Install coupling guard
9. Unlock motor, pump is ready to run.

5.2 LUBRICATION

The packing should be greased every week with 2 to 3 pumps of grease for grease lubricated packing. Lubrication intervals may vary depending on application.

The gear joints are greased at the factory and it is only recommended that they be re-lubricated when they are disassembled.

The bearings on Summit's progressing cavity pumps are grease lubricated and are greased at the factory. These bearings only need to be lubricated when pump is disassembled or every 1500 hours. Fill the bearing cavity only 1/3 full of grease. Upon reassembly, add a few drops of oil to the bearing seals.

Recommended grease lubrication for bearings, gears, pins joints and packing is NLG1 No. 2 consistency grease for pumping temperatures -60°F to 350°F. Grease is not recommended for temperatures above 350°F. Any type of Ep Lithium soap based grease is acceptable. Sodium or Calcium based grease is not. A list of some acceptable bearing grease is shown in **Table 5-1**.

Table 5-1: Acceptable Bearing Greases NLG1 No. 2 Grade

Acceptable Greases	
Citgo	Mystic EP2
Keystone	81EP2
Mobil	Mobilux EP2
Mobil Synthetic	SCH 100

NOTICE

Grease lubricated pumps are intended to use grease only. Do not add oil to the bearing housing

5.3 PACKING

Packing must be lubricated to avoid seizing of packing and failure.

⚠ DANGER

Lock out power to avoid personal injury or death when working on packing

Packing can be grease or water lubricated via flush line.

⚠ CAUTION

Packing must be lubricated to avoid seizing of packing and sealing failure

5.3.1 Greased Packing

A grease zerk is located on the drive end side of the suction housing. The packing should be greased every week or sooner with 2 to 3 pumps of grease. Pumps are shipped with an installed grease zerk in the lubrication port; packing is not lubricated at the factory.

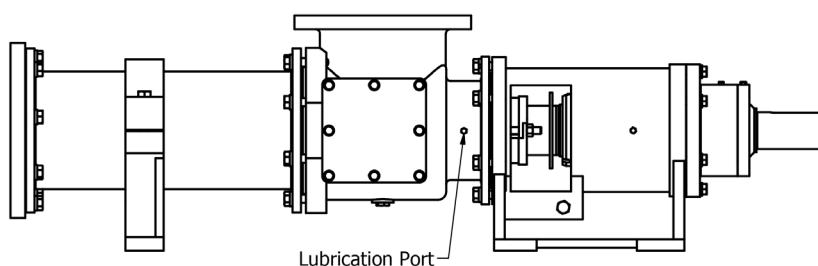

Figure 4

5.3.2 Water Flushed Packing

A water flush is recommended to be used when highly abrasive material is being pumped. The flush will prevent packing leakage and excessive shaft wear. A clean water flush system is shown in **Figure 5-2**. A 1/8" NPT tapped hole in place of the grease zerk is used as the flush inlet. The outlet can either be another tapped NPT hole in the stuffing box or allow the water to leak out near the packing. In either case, this discharge of the flush water should be approximately 10-15 psi higher than the pressure in the suction housing.

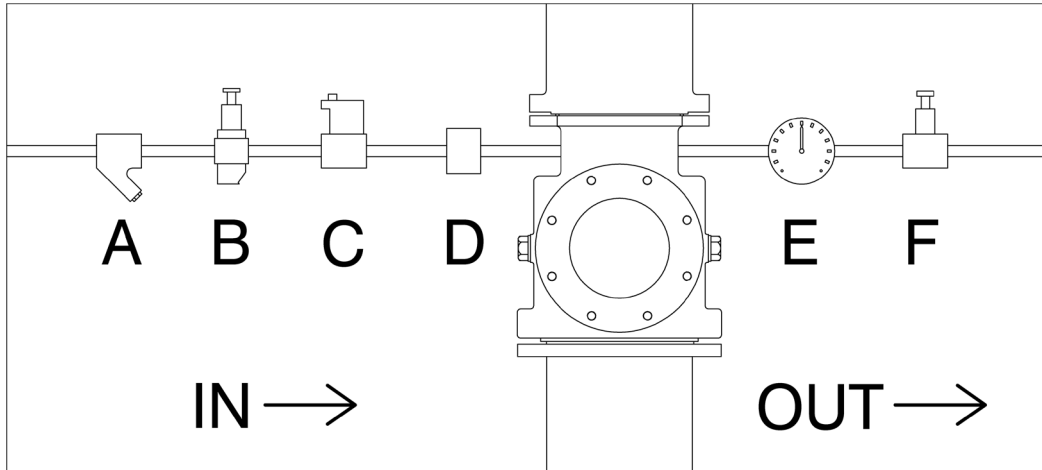

Figure 5: Water Flush System

- A) Y strainer
- B) Pressure regulating valve
- C) Sight flow meter
- D) Solenoid valve
- E) Pressure gauge
- F) Needle valve

5.4 MECHANICAL SEAL

⚠ WARNING
Failure of the mechanical seal could result in serious injury and environmental damage.

⚠ DANGER
Lock out driver power and make sure seal is depressurized before beginning work.

Refer to the manufacturer’s installation, operating, and maintenance instructions. Failure to do so can result in environmental damage, personal injury, and seal malfunction and / or seal failure.

Start Up

Read, understand and follow the manufacturer's installation, operation, and maintenance instructions.

Storage, Assembly and Disassembly

Read, understand and follow the manufacturer's installation, operation, and maintenance instructions.

5.4.1 Type 1 Mechanical Seal

Type 1 mechanical seals require a set distance to obtain the proper pressure on the seal faces. Refer to the seal manufacture to retain the correct seal compression distance. This will locate the set collar on the drive shaft.

5.5 FIRST RUN CHECK

Several items need to be checked before you put your pump into service. Each of the following items needs to be addressed to make certain that your equipment is correctly installed.

1. Proper alignment of pump, coupling, driver and coupling or sheaves.
2. All electrical connections.
3. All interments and gauges should be in working order.
4. Water flush connection to the stuffing box cover (if applicable)
5. Correct pump rotation as indicated on the pump.
6. Open the valves on the suction and discharge.

⚠ DANGER

This is a positive displacement pump.
NEVER operate it against a closed valve

NOTICE

Do not operate pump dry. Dry operation can cause premature damage to the stator

5.5.1 Start Up

1. Before operating the pump it must be filled with liquid. Use the drain plug hole in the suction housing to fill the pump with liquid.
2. Ensure the motor rotation is coincident with the pump rotation.
3. If water packing, turn on water to the stuffing box.
4. Start the pump.

 **DANGER**

Do not operate the pump without the proper guard. See ANSI/ASME B15.1-1996

5.5.2 Shut Down

1. Flush the pump with clean water.
2. Shut down the pump.
3. Close both the discharge and suction valves.
4. If water packing, turn off water to the stuffing box

6 APPENDIX A – MAINTENANCE TIMETABLE

6.1 DAILY MAINTENANCE

1. Check the lip seals on the bearing housing for tears and wear.
2. Inspect the packing or mechanical seal for correct flow, drip rate, noise and pressure.
3. Inspect the gear reducer for temperature and noise.

6.2 THREE MONTH MAINTENANCE

1. Daily maintenance and the following
2. Inspect and adjust packing so that it drips 2 to 5 times per minute. If packing is grease lubricated, lube the packing with 2 to 3 grease gun pumps, weekly.

6.3 SIX MONTH MAINTENANCE

1. Daily maintenance and the following,
2. The packing should be replaced.
3. Check for lip seals and drive shaft for wear. The suction and discharge piping spool pieces should be pulled to inspect the pipe's internal condition.

6.4 YEARLY MAINTENANCE

1. Depending on the fluid pumped and pump operating hours during the year, check pump performance. These inspections can range from once a year to once every three to five years.

7 APPENDIX B – TROUBLESHOOTING

7.1 PUMP PROBLEMS

The pump does not rotate.	1,2,3,4,5,6,7,21,22,24
The pump does not discharge.	8,9,10,11,12,13,14,15,16,21
The discharge output is too low.	1,2,6,7,8,9,10,11,12,13,14,16,17,18,19,21
The discharge output fluctuates.	6,7,8,9,11,13,14,17,18,20,21
The pump drive overloaded.	1,2,3,4,5,6,7,12,16,20,21,22,23
The pump makes excessive noise.	2,6,7,8,9,11,12,13,14,17,19,20,21,23,24,25,26
The shaft seal is leaking.	7,15,26,27,28
Stators wear out too quickly.	4,5,6,7,11,12,14,16,19,20
Rotors wear out too quickly	5,7,11,16,19,20

7.2 PROBABLE CAUSE AND REMEDY.

The power supply is incorrect or the drive is not wired properly. Check the motor nameplate data, test voltage, phase and frequency.	1
There is foreign matter in the pump. The foreign matter needs to be removed.	2
If the pump stator is new there can be too much static friction. The pump should be filled with liquid and turn shaft by hand.	3
The stator is swelled due to chemical attack. The stator should be exchanged for a different material.	4
The stator swelled due to high liquid temp. The liquid temp should be lowered, use undersized rotor.	5
There is a blockage due to solids in the liquid. The solid-to-liquid ratio should be decreased.	6
Leftover liquid settles and hardens in the pump after shutdown. The pump needs to be cleaned and rinsed after the pump is shutdown.	7
The suction pipe is not submerged. The suction pipe needs to be moved so it is submerged.	8
There is air in the suction pipe. The connections need to be tightened,	9
The pump is running to slow. Increase the drive speed.	10
The suction lift is to high causing cavitation. To remedy reduce the suction loss, move the pump to a lower elevation or increase the pump size.	11
The pump is running dry there is no prime. The pump needs to be filled with liquid	12
The stator is worn excessively. The stator needs to be replaced and the rotor needs to be inspected.	13
The rotor is worn excessively. The rotor needs to be replaced.	14
The pump is rotating in the wrong direction. The polarity of the motor needs to be replaced.	15
Pressure of the discharge is too high. The discharge valve needs to be opened, shorten the length of the discharge pipe, remove any obstructions from pipe or replace pipe with a larger size.	16
The suction pipe is leaking. Tighten the pipe fittings.	17
The Shaft packing is leaking. The packing gland needs to be tightened, replace the packing or the packing need lubrication.	18
The material of the stator is brittle. The stator needs replacement.	19
The speed of the pump is too high. The drive speed needs to be reduced.	20
The viscosity or specific gravity is too high. Measure the liquid and compare it with specification.	21
The packing is too tight. The gland nuts need to be loosened and the packing lubricated.	22
The drive shaft is bent. The drive shaft needs to be replaced.	23
Misalignment of the pump. The pump and drive need to be realigned.	24
The flexible drive coupling is worn. Replace the coupling.	25
The packing is incorrect. Change out the packing material.	26
The packing is to loose. The gland nuts need to be tightened and the packing lubricated.	27

8 APPENDIX C – DISASSEMBLY MODEL SPPC

8.1 DISASSEMBLY MODEL SPPC

(PROCEDURE AND PARTS MAY VARY BY PUMP SIZE)

1. Follow shutdown procedures on page 13.
2. Disconnect pump from the power source.



3. Remove the drain plug or Inspection Plate (32) and Gasket (33) to drain the pump of fluids.
4. Remove Hex Nut Packing (F), Stud Packing (H) and Packing Gland Halves (21) from the stuffing box.
5. Remove the Packing (22) with a pair of flexible packing extractors by placing each one spaced evenly apart and pull out evenly.
6. The Lantern Ring Halves (23) need to be removed next with the flexible packing extractors. Then remove the remaining packing rings.
7. Remove a section of the discharge pipe connected closest to the Discharge Flange (37).
8. The top half of the Stator Support (31) comes off next.
9. From the Suction Housing (29) unbolt the Stator Clamp Ring (36A) and remove the Stator Gasket (34).
10. The stator Retaining Ring (35) can be removed with the tip of a flat head screwdriver.
11. The Stator Clamp Ring (36B) needs to be removed from the Stator (30).
12. Unbolt the Stator Clamp Ring (36B) and remove the Stator Gasket (34), Stator Retaining Ring (35), and Stator Clamp Ring (36B) from the Stator (30).
13. Remove the Stator (30) and Rotor (40) assembly. The Stator (30) and Rotor (40) need to be inspected for damage and wear. Checking Stator (30) wear can be precarious. Worn stators could appear torn, pitted, grooved or even smooth as when it was new. A performance check is the best way to determine stator wear/Stator (30) and Rotor (40) fit.

To check for rotor wear the crest to crest measurement will be taken, as shown in Figure 7, using an inspection block. Subtract inspection block thickness from measured result and compare with Table 8-1 below. If the calculated value is within 0.010 inch of the crest to crest value in Table 8-1 the Rotor (40) can be reused. If measurement is less than 0.010 inch replace the Rotor (40). Additionally, if the key slots are excessively worn, rotor surface is cracked, has pits or has deep grooves, regardless of crest to crest measurement, the Rotor (40) should be replaced.

Table 8-1: Crest to Crest Values

Rotor Size Designation	Crest to Crest Value "S" (inches)
008	2.772 ^{+0.000} / _{-0.004}
012	2.676 ^{+0.000} / _{-0.004}
022	3.425 ^{+0.000} / _{-0.004}
036	4.015 ^{+0.000} / _{-0.004}
050	4.015 ^{+0.000} / _{-0.004}
065	4.906 ^{+0.000} / _{-0.004}
090	4.906 ^{+0.000} / _{-0.004}
115	5.709 ^{+0.000} / _{-0.004}
175	6.584 ^{+0.000} / _{-0.004}
335	5.800 ^{+0.000} / _{-0.005}
345	7.260 ^{+0.000} / _{-0.004}
620	7.128 ^{+0.000} / _{-0.005}
800	7.658 ^{+0.000} / _{-0.004}

Values are for AAA trim codes only

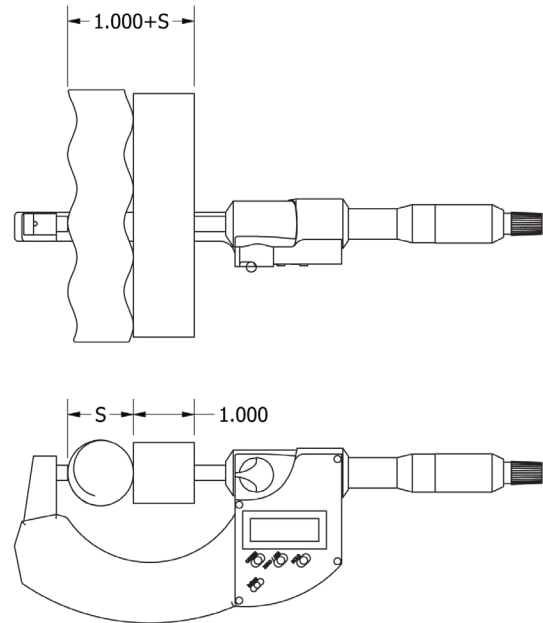

Figure 6: Crest to Crest Measuring

14. Disassemble the V-Belts and pulley or coupling and remove it from the drive shaft.
15. Take out the Pipe Plugs (C) from the Drive Shaft (14) and Drive Shaft Head (04).
16. Unscrew the Set Screw (D) from the Drive Shaft (14).
17. On the Drive Shaft Head (04) remove the Socket Head Screws (E) the pull off the Drive Shaft Head (04) and Primary Thrust Plate (06) and Keys (7) from the Drive Shaft Head (04).
18. Disengage the Locknut (09) from the Connecting Rod (38). Take out the Ring Gear (08), Ball Gear (10), Secondary Thrust Plate (11), Seal Support (12), and Gear Joint Seal (13).
19. Remove the connecting rod/rotor assembly pulling from the discharge end of the pump.
20. Unscrew the Vent Plug (C) and Set Screws (D) from the Gear Joint Shell (39).
21. Take out the Socket Head Cap Bolt (T) from the Head Ring (42) and pull out the O-ring (41).
22. Remove the gear joint assembly/connecting rod from the rotor head. Take out the Gear Joint Keys (07) and Primary Thrust Plate (06) from the Rotor (40).
23. Remove the Gear Joint Shell (39) from the gear ball/connecting rod assembly and remove the Ring Gear (08) off the Ball Gear (10).
24. Secure the Connecting Rod (38) in a vice or hold it with a pipe wrench and remove the Lock Nut (09). Slide off the Ball Gear (10), Secondary Thrust Plate (11), Seal Support (12), and Gear Joint Seal (13) off the Connecting Rod (38).
25. Unscrew the Six Hex Head Bolts (A) from the Bearing Cover Plate (02). Remove the Bearing Cover Plate (02) with Radial Grease Seal (01) and O-ring (03) off the Drive Shaft (14).
26. Take the drive shaft/bearing assembly out of the bearing housing. Simultaneously, slide the Slinger Ring (20) from the Drive Shaft (14). Take out the Thrust Grease Seal (19) from the Bearing Housing (26).

27. Unscrew the four Hex Head Bolts (O) from the pump Clamp Ring (28), and four fasteners securing the Bearing Housing (26) to base. Remove the Bearing Housing (26) from the Suction Housing (29) until the Bearing Housing (26) clears the stuffing box.
28. Unscrew the Bearing Set Screw (17) from the Bearing Lock Nut (18). With a spanner wrench or punch and hammer, thread the lock nut off the drive shaft.
29. Take off both halves the Bearing Spacer (16) from the shaft and press the Roller Bearings (15) off the Drive Shaft (14).

9 APPENDIX C – ASSEMBLY MODEL SPPC

9.1 ASSEMBLY MODEL SPPC

(PROCEDURE AND PARTS MAY VARY BY PUMP SIZE)

The assembly procedure is the inverse of the disassembly procedure. The following are general guidelines in completing the assembly process. It is recommended that all wearable items such as: gear joint seals (13), O-Rings (03) (41) and O-Ring Shaft Head (05) are replaced when either gear assembly is disassembled.

It is vital during assembly to ensure cleanliness is a priority. Especially for the gear joints and bearings to avoid unnecessary failure of the pump.



9.1.1 Lubrication

1. Pack bearings after installation on shaft. Bearing should be filled half full of grease ensuring all rollers and bearing faces are covered. **Do not over fill bearings.**
2. Gear joints must be packed during assembly. **Vent plug (C) must be removed to allow venting of excess grease during assembly of gear joints. (Section 9.1.6 step 12)**
3. Packing rings should be lubricated to assist with assembly. Lubrication is also needed via grease zerks once pump is assembled if grease lubricated (See Section 5.3 for lubrication styles).

9.1.2 Packing

1. Apply thin coating of lubricant to packing rings. Insert two rings with their splits **90 degrees apart from each other.**
2. Insert lantern ring halves.
3. Insert last four packing rings. It may be necessary to run the pump to allow the Packing (22) to compress enough to insert the final packing ring.
4. Thread in Studs, Packing (H), Packing Gland Halves (21) and hand tight thread on Hex Nuts, Packing (F) onto the packing studs.

9.1.3 Suction & Bearing Housing

This may be completed with or without the bearing/drive shaft assembly installed in the bearing housing.

1. Set Clamp Ring (28) over the stuffing box and install Retainer Ring (27) in groove on the Suction Housing (29).
2. Insert machined OD of Suction Housing (29) into Bearing Housing (26). Line up Clamp Ring (28) holes with the threaded holes on the Bearing Housing (26). Hand tighten Hex Head Bolt (O) and Lock Washer (OO).
3. Rotate Suction Housing (29) to desired angle and tighten Hex Head Bolts (O) to predetermined torque per application.

9.1.4 **Bearing/Drive Shaft Assembly**

1. Press first Taper Roller Bearing (15) onto shaft ensuring proper orientation. (For G drive and larger, bearing needs to be heated to 250° F for assembly). Place cup on rollers, place Bearing Spacer (16) halves on cup and place second cup on spacers.
2. Press second Taper Roller Bearing (15). **Bearing face should not pass shoulder on shaft.** Thread Bearing Lock Nut (18) on Drive Shaft (14) and tighten until it sets on the shoulder of the shaft. Install/tighten the Bearing Set Screw (17) in the lock nut.
3. Remove Bearing Spacer (16) halves and pack Taper Roller Bearings (15) with grease. Install one half of Bearing Spacer (16) on Drive Shaft (14) and fill space between bearings with grease. Install other half of Bearing Spacer (16).
4. Insert Radial Grease Seal (01) and Thrust Grease Seal (19) into the Bearing Cover Plate (02) and Bearing Housing (26), respectively, with the spring facing outward (visible).
5. Install Drive Shaft (14) assembly into the Bearing Housing (26). **Do not damage the lip seals.**
6. Install O-Ring (03) onto the Bearing Cover Plate (02) and tighten Hex Head Bolts (A) and Lock Washers (AA) evenly. Ensure O-Ring (03) is properly seated to make the needed seal of the bearing cavity in the Bearing Housing (26), ideally there should be 0.010”-0.020” gap between the Bearing Cover Plate (02) and the Bearing Housing (26). *Install a sleeve on the Drive Shaft (14) at this point, if required.*

9.1.5 **Rotor/Stator**

1. Put Head Ring (42) on by sliding it over the profile of the Rotor (40). Ensure proper orientation to accept Socket Head Bolts (T).
2. Place Stator Ring Clamp (36A) and Stator Clamp Ring (36B) along with the two Retainer Rings (35) holding the clamps in place for the moment.
3. Insert the Rotor (40) into the Stator (30). For ease of installation, rotate the Rotor (40) counterclockwise during assembly along with an application, on the rotor, of compatible lubricant of the soft stator material is recommended.

Note: Rotor head should remain approximately 4”-7 ½” out of the stator in order to connect to the gear joint. Adjustments can be made by rotating the stator if needed.

9.1.6 **Rotor Gear Joint**

1. Place the O-Ring (41) over the Rotor (40) head and allow to hang loose with the Head Ring (42). Insert the Primary Thrust Plate (06) into the rotor head and ensure the end face of the Rotor (40) is flush with the Primary Thrust Plate (06). If these faces are not flush take out the Primary Thrust Plate (06) and check for debris in the rotor head.
2. On the Connecting Rod (38) slide the Gear Joint Seal (13) into the Connecting Rod Bushing (43). Apply a small amount of approved gear joint lubricant to the side opposite the Connecting Rod (38).
3. Use the same lubricant to the Seal Support (12) on the flat face and slide it onto the Connecting Rod (38) such that the flat face and radius of the Seal Support (12) is touching the Gear Joint Seal (13).
4. Grease the spherical surface of the Sec. Thrust Plate (11) to which the Ball Gear (10) mates and position the thrust plate against the Gear Joint Seal (13). Ensure the seal is able to make a snug connection to the thrust plate.
5. Grease the spline of the ID of the Ball Gear (10) and slide the gear onto the Connecting Rod (38). The counter bore in the Ball Gear (10) should be facing the connecting rod such that the gear fits over the shoulder on the Connecting Rod (38). Thread on the lock nut and tighten against the Ball Gear (10). Grease the spherical surfaces and outer gear of the Ball Gear (10).

6. Grease the teeth of the Ring Gear (08) and install onto the Ball Gear (10). Ensure when assembled the opening for the Keys (07) are facing the Rotor.
7. Grease the spherical surface of the Primary Thrust Plate (06) and fill the remaining volume in the rotor head with grease.
8. Slide the Gear Joint Shell (39) over the length of the Connecting Rod (38) and gear joint assembly ensuring the Gear Joint Seal (13) rests against the Gear Joint Shell (39). The two tapped holes in the Gear Joint Shell (39) should line up with one of the Keys (07) in the Gear Ring (08).
9. Install the Keys (07). Ensure the Gear Joint Shell (39) tapped holes are in line with at least one of the Keys (07).
10. Aline Keys (07) with the keyway in the rotor head and insert the Connecting Rod (38) and gear assembly into the rotor head. Ensure the Keys (07) remain engaged correctly.
11. Aline the tapped set screw hole of the Gear Joint Shell (39) with the shallow hole on the rotor head. Thread in the Set Screw (S) until light contact is made on the rotor head.
12. Install the O-Ring (41) into the shoulder of the Gear Joint Shell (39). Fit the Head Ring (42) to the Gear Joint Shell (39) and install the Socket Head Bolts (T). Tighten evenly and confirm that the O-Ring (41) remains in place. When finished, a gap of a few thousands of an inch between the Head Ring (42) and the Gear Joint Shell (39) should be present.

Note: Vent plug must be removed during this step.

13. While Socket Head Bolts (T) are being tightened, excess grease will protrude from the Gear Joint Shell's (39) vent hole. Tighten the Set Screw (S) and move the Connection Rod (38) randomly to ensure proper assembly and remove any excess grease through the vent plug hole.
14. Install the Pipe Plug (C) in to the vent hole on the Gear Joint Shell (39) and tighten.

9.1.7 Rotor/Stator to Drive End

1. Place Retainer Rings (35) on both ends of Stator (30) into provided grooves with Stator Ring Clip (36A) and Stator Clamp Ring (36B) around Stator (30) in between Retainer Rings (35) if not done so already.
2. Install Stator Gasket (34) in groove of mating part of the Stator (30).
3. Slide the rotor/stator/connecting rod assembly into the Suction Housing (29) while inserting the Connecting Rod (38) into the Drive Shaft (14). Align Stator (30) with mating bore on the Suction Housing (29) and ensure Stator Gasket (34) is properly in place.
4. Tighten the Hex Head Bolts (R) and Lock Washers (RR) evenly to secure the Stator (30).

9.1.8 Gear Joint: Drive End

1. Slide the Gear Joint Seal (13) onto the Connecting Rod (38) fitting it into the Connecting Rod Bushing (43).
2. Grease the Gear Joint Seal (13) with a light film of gear joint grease to the inside of the seal and Seal Support (12). Slide the Seal Support (12) onto the Connecting Rod (38) oriented so the flat face sits against the seal.
3. Grease a thin layer of gear joint grease to the Secondary Thrust Plate's (11) spherical surfaces. Then slide the thrust plate into the Drive Shaft (14) until it rests against the Gear Joint Seal (13).
4. Grease a thin layer of grease to the spline of the Ball Gear (10) and grease its spherical surfaces and outer gear teeth with a liberal amount of grease. Slide the Ball Gear (10) onto the Connecting Rod (38) with the counter bore of the Ball Gear (10) facing the Connecting Rod (38). Ensure it rests firmly against the Secondary Thrust Plate (11). Thread on the Lock

Nut (09) and tighten it to the Ball Gear (10). When tightening, ensure the Connecting Rod (38) does not rotate by carefully holding it with a pipe wrench through any of the inspection ports in the Suction Housing (29).

5. Grease a liberal amount of grease to the teeth of the Ring Gear (08) and slide it over the Ball Gear (10). Ensure the keyway openings are facing out (towards the drive end) with one of the keyways in line with the tapped holes in the Drive Shaft's (14) largest diameter.
6. Position the Keys (07) in the keyway of the Ring Gear (08). The flat face of the Ring Gear (08) should approximately be flush with the end of the Drive Shaft (14).
7. Lightly tap in an expansion pin, in not already, into the pin hole that is drilled in the Drive Shaft Head (04). Position the Primary Thrust Plate (06) into the Drive Shaft Head (04) such that the groove or drilled hole in the Primary Thrust Plate (06) lines up with the expansion pin.
8. Lightly Grease the spherical surface of the Primary Thrust Plate (06). Fill the remaining central volume of the Drive Shaft Head (04) with grease.
9. Place the O-Ring Shaft Head (05) in the provided groove on the Drive Shaft Head (04). Align the keyways of the Drive Shaft Head (04) with the Keys (07) in the Gear Ring (08) and insert the Drive Shaft Head (04) into the Drive Shaft (14).

Note: Ensure the threaded holes of the Drive Shaft (14) and the Drive Shaft Head (04) are in line with each other. If not, carefully use a strap or pipe wrench to turn the Drive Shaft (14).

10. Thread in the Socket Head Bolts (E) through the Drive Shaft Head (04) and into the Drive Shaft (14). Tighten evenly until the Drive Shaft Head (04) is tightly rested against the face of the Drive Shaft (14). Excess grease should expel from the vent hole in the Drive Shaft (14) and the Drive Shaft Head (04).

Note: **Pipe Plugs (C) must be removed during this step to generate the correct amount of grease in the gear joint assembly.**

If the Socket Head Bolts (E) are not long enough to reach the tapped holes in the Drive Shaft (14), two longer bolts, positioned 180 degrees apart from each other, can be used until the Drive Shaft Head (04) is close enough for the Socket Head Bolts (E) to thread in.

11. Wipe expelled grease from the exterior of the Drive Shaft Head (04) and Drive Shaft (14) and install Pipe Plugs (C). Also at this time, install the Set Screw (D) in the Drive Shaft (14) to secure the Secondary Thrust Plate (11).

9.1.9 Stator Support & Discharge

1. Assemble the top half of the Stator Support (31) over the bottom half and tighten the Hex Head Bolts (L) securing the Stator Support (31) assembly.
2. Position the Stator Gasket (34) in the Discharge Flange (37) and set onto the end of the Stator (30). Align holes in the Stator Clamp Ring (36B) and Discharge Flange (37) and secure using Hex Head Bolts (M) and Lock Washers (MM).

9.1.10 Final Steps

1. Assemble Inspection Plates (32) a top Inspection Plate Gaskets (33) onto the Suction Housing (29) using Hex Head Bolts (P) and Lock Washers (PP).
2. Install all Pipe Plugs (Q) (J) (N) and zerk fittings in the stuffing box (see **Figure 5-1**) if packing is grease lubricated.
3. Check over pump ensuring all parts, bolts and fittings are secure

4. Connect the power source, start the flow of the flush water (if used). Ensure the suction and discharge valves are open. Start the pump.

 **DANGER**

Operation of any progressive cavity pump with a clogged discharge or closed discharge valve generates a pressure vessel.

10 APPENDIX D – SECTION VIEW SPPC

(PARTS MAY VARY BY PUMP SIZE)

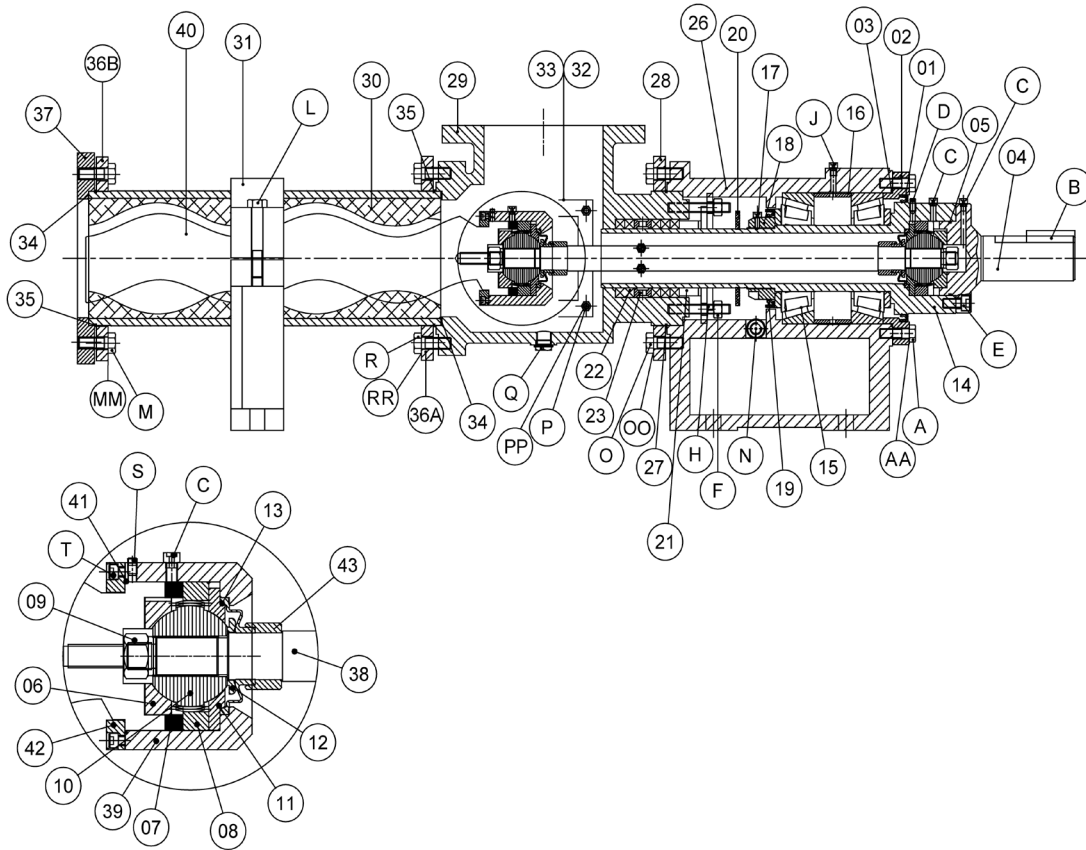

MODEL SPPC SEALED GEAR JOINT PUMP PARTS LIST					
ITEM	DESCRIPTION	ITEM	DESCRIPTION	ITEM	DESCRIPTION
01	RADIAL GREASE SEAL	23	LANTERN RING HALF	B	Shaft Key
02	BEARING COVER PLATE	26	BEARING HOUSING	C	Pipe Plug
03	O RING	27	RETAINER RING	D	SET SCREW
04	DRIVE SHAFT HEAD	28	CLAMP RING	E	Socket Head Bolt
05	O RING SHAFT HEAD	29	SUCTION HOUSING	F	Hex Nut, Packing
06	PRIMARY THRUST PLATE	30	STATOR	H	Stud, Packing
07	KEY	31	STATOR SUPPORT	J	Pipe Plug
08	RING GEAR	32	INSPECTION PLATE	L	Hex Head Bolt
09	CON-ROD LOCK NUT	33	INSPECTION PLATE GASKET	M	Hex Head Bolt
10	BALL GEAR	34	STATOR GASKET	MM	Lock Washer
11	SEC. THRUST PLATE	35	RETAINER RING	N	Pipe Plug
12	SEAL SUPPORT	37	DISCHARGE FLANGE	O	Hex Head Bolt
13	GEAR JOINT SEAL	38	CONNECTING ROD	OO	Lock Washer
14	DRIVE SHAFT	39	GEAR JOINT SHELL	P	Hex Head Bolt
15	TAPPER ROLLER BEARING	40	ROTOR	PP	Lock Washer
16	BEARING SPACER	41	O RING	Q	Pipe Plug
17	BEARING SET SCREW	42	HEAD RING	R	Hex Head Bolt
18	BEARING LOCK NUT	43	CONNECTING ROD BUSHING	RR	Lock Washer
19	THRUST GREASE SEAL	36A	STATOR RING CLIP	S	Set Screw
20	SLINGER RING	36B	STATOR CLAMP RING	T	Socket Head Bolt
21	PACKING GLAND HALF	A	Hex Head Bolt		
22	PACKING	AA	Lock Washer		

11 APPENDIX E – DIMENSIONS

11.1 Stuffing Box

DRIVE END SIZE	STANDARD W/O SHAFT SLEEVE							
	SS	SX	SK	SI	SQ	ST	SP	SH
SPE	2.250	3.250	2.31	4.19	4.37	3/8-16UNC	5.00	5.500
SPF	2.750	3.750	2.81	4.44	5.00	3/8-16UNC	5.87	6.589
SPG	3.250	4.500	3.31	4.94	5.87	1/2-13UNC	6.75	7.498
SPH	3.750	5.000	3.86	4.94	6.50	5/8-11UNC	7.50	8.589
SPJ	4.500	6.000	4.56	5.75	7.75	5/8-11UNC	8.75	9.500
SPK	4.625	7.000	5.31	6.81	9.00	3/4-10UNC	10.13	11.000

NOTE: GLAND DIAMETER MAY NOT BE ANY LARGER THAN "SP" DIMENSION.
ALL DIMENSION IN INCHES.

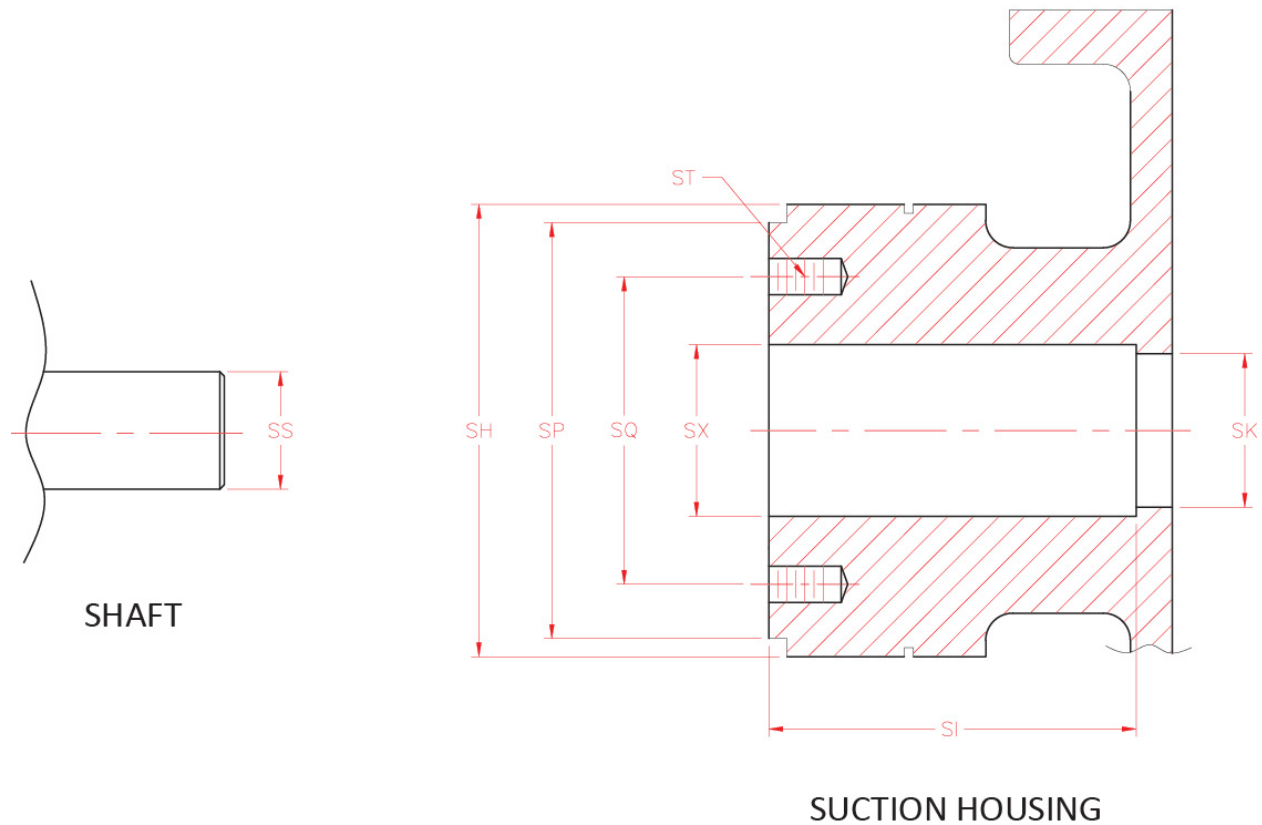

11.2 Overall Dimensions

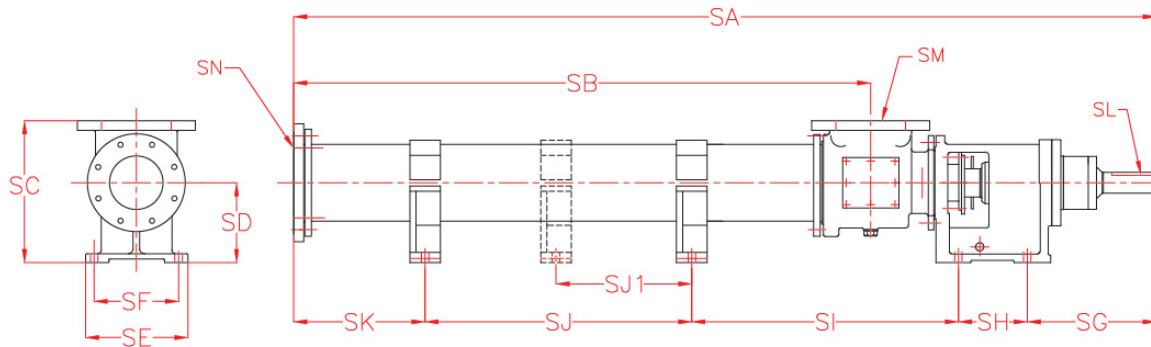

FRAME	SIZE	SA ±0.25	SB ±0.12	SC	SD	SE	SF	SG	SH	SI	SJ	SJ1	SK	Ø SL	SUCTION	DISCHARGE
															SM SIZE	SN SIZE
E FRAME	4SPE008	63.50	37.63	11.50	6.00	8.00	6.50	11.94	5.50	18.00	18.00	-	10.06	1.88	4.00	4.00
	1SPE012	42.00	16.12													
	2SPE012	53.12	27.25													
	4SPE012	75.62	49.75													
	6SPE012	97.88	72.00													
	1SPE022	43.31	17.19													
	2SPE022	56.19	30.06	12.50	6.00	8.00	6.50	11.94	5.50	18.00	-	-	7.88	6.00	6.00	
	4SPE022	82.94	56.81													
	6SPE022	108.44	82.31													
	1SPE036	46.09	19.50													
	1SPE050	51.53	24.93	13.00	7.00	10.00	8.50	13.00	6.75	-	-	-	-	2.12	8.00	8.00
	2SPE050	71.34	44.74													
	2SPE065	71.98	41.49													
	1SPE175	117.00	33.85													
F FRAME	6SPF012	102.38	72.50	13.50	7.00	10.00	8.50	13.00	6.75	67.00	-	-	15.63	2.12	6.00	6.00
	4SPF022	86.69	56.81													
	6SPF022	112.19	82.31													
	1SPF036	48.62	19.62	14.00	7.00	10.00	8.50	13.00	6.75	21.00	-	-	7.88	2.12	6.00	6.00
	2SPF036	63.12	34.12													
	4SPF036	92.12	63.12													
	1SPF050	53.94	24.94													
	2SPF050	73.75	44.75	15.50	7.00	10.00	8.50	13.00	6.75	20.00	25.00	-	9.00	2.12	6.00	6.00
	4SPF050	113.50	84.50													
	1SPF090	60.71	30.21													
	1SPF090	60.71	30.21													
G FRAME	2SPG036	67.80	35.68	16.00	9.00	11.50	9.50	14.50	7.75	30.00	-	-	15.55	2.38	6.00	6.00
	6SPG022	116.87	84.75													
	4SPG036	97.06	64.94													
	6SPG036	125.81	93.69													
	2SPG050	78.25	46.12													
	4SPG050	118.44	86.31													
	6SPG050	158.19	126.06	17.50	9.00	11.50	9.50	14.50	7.75	30.00	82.00	-	23.94	2.38	6.00	6.00
	1SPG065	56.88	23.75													
	2SPG065	74.75	41.62													
	4SPG065	110.63	77.50													
	1SPG090	63.38	30.25													
	2SPG090	87.88	54.75													
	1SPG115	62.25	29.19													
	1SPG115	62.25	29.19													

INSTALLATION, OPERATION, AND MAINTENANCE MANUAL

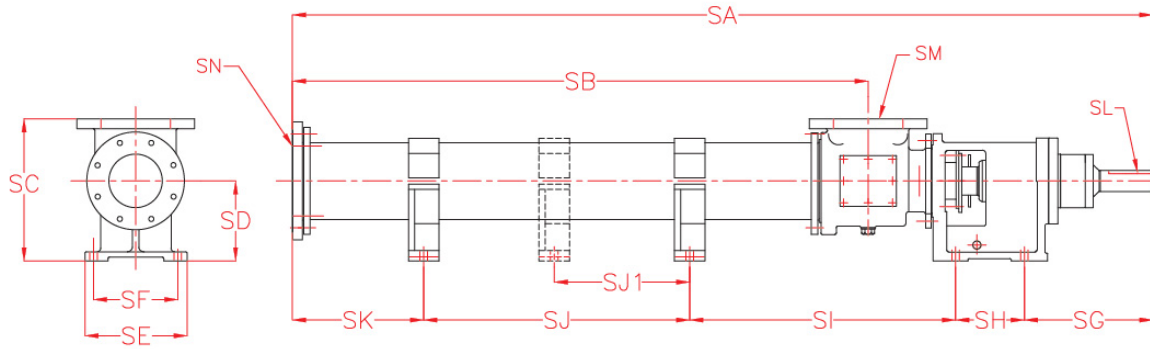

FRAME	SIZE	SA ±0.25	SB ±0.12	SC	SD	SE	SF	SG	SH	SI	SJ	SJ1	SK	Ø SL	SUCTION	DISCHARGE
															SM SIZE	SN SIZE
H FRAME	6SPH036	131.00	95.38	19.50	11.00	15.00	13.00	15.12	9.50	27.00	70.00	35.00	9.38	2.88	8.00	6.00
	4SPH065	115.12	79.50							35.00	35.00	-	20.50			
	6SPH065	150.62	115.00							35.00	80.00	-	11.00			
	2SPH090	92.00	56.38							57.00	-	-	10.38			
	4SPH090	141.50	105.88							30.00	72.00	-	14.88			
	6SPH090	190.50	154.88							35.00	110.00	-	20.88			
	1SPH115	65.87	30.88							30.00	-	-	11.25			
	2SPH115	89.88	54.25							30.00	24.00	-	11.25			
	4SPH115	136.62	101.00							30.00	72.00	36.00	10.00			
	2SPH175	97.69	60.37							21.50	30.00	30.00	-			13.34
J FRAME	6SPJ065	155.94	116.16	19.50	11.00	15.00	13.00	16.00	12.00	34.00	80.00	40.00	13.94	3.38	8.00	8.00
	4SPJ090	145.90	106.15							30.00	72.00	OL	15.90			
	6SPJ090	195.25	155.38							30.00	120.00	-	17.25			
	2SPJ115	94.95	55.20							-	-	-	-			
	4SPJ115	141.88	102.00							30.00	72.00	-	11.75			
	6SPJ115	188.62	148.75							30.00	110.00	-	20.40			
	1SPJ175	74.75	33.88							30.00	-	-	16.75			
	2SPJ175	101.38	60.50							30.00	30.00	-	13.38			
	4SPJ175	154.62	113.75							30.00	80.00	-	16.63			
	1SPJ345	94.25	53.37							-	-	-	-			
2SPJ345	140.21	99.33	21.50	15.00	13.00	16.00	-	-	-	-	10.00	10.00				
K FRAME	6SPK115	202.06	152.25	23.50	13.00	17.00	14.50	21.00	15.00	42.50	108.00	54.00	15.75	3.88	10.00	8.00
	4SPK175	167.19	117.38							37.25	80.00	40.00	14.12			
	6SPK175	220.19	170.38							37.25	120.00	60.00	27.12			
	2SPK345	153.34	102.38							48.00	42.00	-	26.34			10.00

*All dimensions are in inches

12 TORQUE GUIDELINES

12.1 Bolt Torques

Bolt Size	Stainless Steel Bolts ASTM F593	Carbon Steel Bolts SAE J429 Grade 5/ ASTM A449
Size	Max. Torque	Max. Torque
10-24	22 inlb	-
10-32	33 inlb	-
1/4-20	72 inlb	101 inlb
5/16-18	149 inlb	209 inlb
3/8-16	22 ftlb	31 ftlb
7/16-14	35 ftlb	49 ftlb
1/2-13	54 ftlb	75 ftlb
9/16-12	78 ftlb	109 ftlb
5/8-11	107ftlb	150 ftlb
3/4-10	132 ftlb	266 ftlb
7/8-9	212 ftlb	429 ftlb
1-8	318 ftlb	644 ftlb

12.2 Connecting Rod Lock Nuts

(Ensure locknut is set securely against ball gear.)

Connecting Rod Lock Nuts		
Frame Size	Nut	Max. Torque
E	9/16-18	25 ftlb
F	3/4-16	35 ftlb
G,H	7/8-14	50 ftlb
J	1 1/4-12	85 ftlb
K	1 1/2-12	110 ftlb

PUMP INFORMATION

Purchase Date: _____

Purchase Order#: _____

Serial Number: _____

Equipment Number: _____

PO Box 12145 Green Bay, WI 54307

www.summitpump.com

Rev. 08/2023



